

National Lighting®

INSTALLATION INSTRUCTIONS

For DOCK-900 Wireless Charger

Input rating: DC 5V, 2A / 9V, 1.75A (Quick Charge power adapter)

Output rating: 5 watts / 10 watts (Quick Charge power adapter)

CAUTION: To prevent the risk of fire and electric shock, please be sure to read all instructions before installing or using this unit.

IMPORTANT SAFETY INSTRUCTIONS

WARNING – To reduce the risk of fire, electric shock, or injury to persons:

1. Do not use power supply and cord(s) from 3rd party to connect the unit(s)
2. Do not try to open the unit
3. Do not place any metal objects on the wireless charging surface

MOUNTING

Note: the distance between the top of the charger and the desktop surface must be less than 1/8".

1. Route a hole using the specifications from the illustrations on the right.
2. Push the charger into the hole with the input jacks facing the notches.
3. Turn the knob on the mounting bracket counter-clockwise to lower the mounting bolt and position the bolt with the center of the charger. Secure the mounting bracket by 2 tapping screws.
4. Turn the knob on the mounting bracket clockwise to raise the bolt and secure the charger to the hole. Do not over-tighten the knob/bolt as it may damage the charger.
5. Connect the power adapter to the input jack on the charger.
6. Mark the center of the charger on the desktop surface to indicate the charging spot.

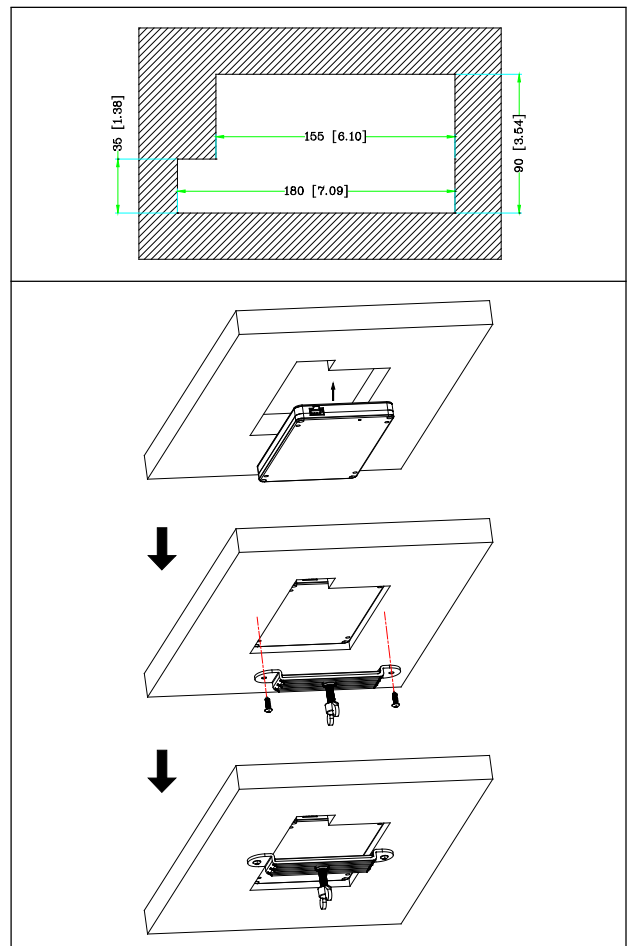

USING THIS WIRELESS CHARGER

1. Plug the power adapter to nearest wall outlet.
2. The LED indicator will flash briefly indicating the charger is correctly powered up.
3. Place the Qi wireless charging capable device on the marked location of the desktop surface. Blue indicator will be on. Once the device is fully charged, the LED turns green indicating the charging is completed (green indicator works with compatible devices with status feedback functions only).

This device complies with part 15 of the FCC Rules. Operation is subject to the following two conditions: (1) This device may not cause harmful interference, and (2) this device must accept any interference received, including interference that may cause undesired operation.

CAUTION: Changes or modifications not expressly approved by the party responsible for compliance could void the user's authority to operate the equipment.

Note: This equipment has been tested and found to comply with the limits for a Class B digital device, pursuant to part 15 of the FCC Rules. These limits are designed to provide reasonable protection against harmful interference in a residential installation. This equipment generates, uses and can radiate radio frequency energy and, if not installed and used in accordance with the instructions, may cause harmful interference to radio communications. However, there is no guarantee that interference will not occur in a particular installation. If this equipment does cause harmful interference to radio or television reception, which can be determined by turning the equipment off and on, the user is encouraged to try to correct the interference by one or more of the following measures:

- Reorient or relocate the receiving antenna.
- Increase the separation between the equipment and receiver.
- Connect the equipment into an outlet on a circuit different from that to which the receiver is connected.
- Consult the dealer or an experienced radio/TV technician for help.

This equipment complies with FCC radiation exposure limits set forth for an uncontrolled environment. This equipment should be installed and operated with minimum distance 20cm between the radiator & your body.

Please contact with National Lighting Corp. at (888) 428-6886 for assistance if any question occurs during installation.